



WINDOW & DOOR SYSTEMS

*Innovations*

WINDOW & DOOR SYSTEMS



# THE *Innovations* STORY



Innovations Windows & Doors were created to blend style with performance...features with benefits aimed at providing ultimate comfort for your home.

Over the years, discriminating homeowners have sought products that delivered warm architectural features, greater energy efficiency, and were produced with more "green" manufacturing practices. As the window industry has evolved, many revolutionary technologies have been developed to meet the demands of today's market. The result is the Hybrid technology fused together in the development of the Innovations Window. Innovations combines Carbon Composite Reinforcements, Premium UPVC extrusions, and Earth-friendly insulation to deliver a state of the art window system. Innovations answers the quest to provide today's comfort with care for tomorrow.

Innovations...a smart investment for today, tomorrow, and many generations to follow.

The word "HYBRID" is written in a bold, white, sans-serif font with a green leaf-like graphic element above the letter 'I'.

**HYBRID**



## Why should I replace my windows with Innovations?

### *To Save Money*

Older less efficient windows are costing you money in heating and cooling costs every day. In addition with energy cost rising, your lost energy costs are growing larger each day. Every day you enjoy the thermal and structural technology of the Innovations window you are paying yourself back for the investment. In other words, you are paying for new windows right now, whether you have them or not.

### *To Eliminate Maintenance*

Innovations windows are made from UPVC profiles which will never rot, splinter, warp or require any maintenance...ever. In addition, the Conservision Glass used in the Innovations is so trouble free, we guarantee it's performance for as long as you own your home...and beyond. The conservision glass is absolutely the best made, highest efficiency glass available today. In fact, the seal failure rate is 900 percent better than our closest competitor. Plus, all of our windows are built with double strength double pane glass where most manufactures use only single strength glass...better noise protection and stronger against accidental breakage.

### *For Better Living*

All Innovation windows will operate easily and smoothly. Also, the double hung windows tilt in (both sashes) for easy cleaning and the Horizontal Sliders will lift out for ease of cleaning. If you are tired of windows that just do not work right...Innovations is the clear choice.

### *House Beautiful*

New windows with clean smooth lines will add to the curb appeal of your home. Innovation windows have been designed to blend with your home's exterior and interior to compliment the original architectural mill work detail. Always bright, always clean surfaces will enhance your home inside and out.

### **Summary of Benefits:**

- **Immediate Return on Investment**
- **Energy Payback**
- **Maintenance Free**
- **Easy Operation**
- **More Comfortable Living**
- **Enhance the Beauty of Your Home**
- **Noise Reduction**



# Innovations DOUBLE-HUNG WINDOWS

## TRADITION MEETS TECHNOLOGY

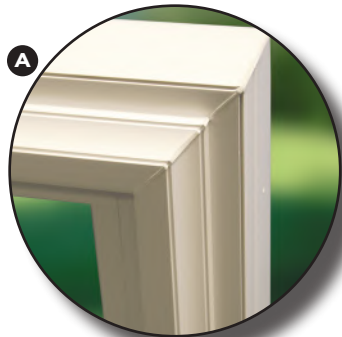

### Exceptional Beauty

- Exterior Contoured Frame **A** is fusion welded.
- Equal Sight Lines between upper and lower sash.
- High Performance Sloped Sill with sash interlock.
- Sash detailing offers Traditional millwork appearance.
- Shadow grooved sash corners at weld locations.
- Contoured Lift Rails on both sashes.

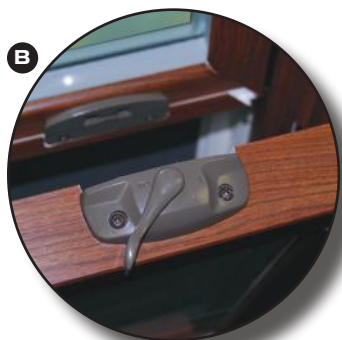

### Superior Performance

- **INNERGY™ C** Composite Reinforcements at meeting rail.
- **Magna-Tite™ D** bottom sash weather-strip.
- **Insul-Core™ E** frame insulation.
- Triple weather-stripped sash.

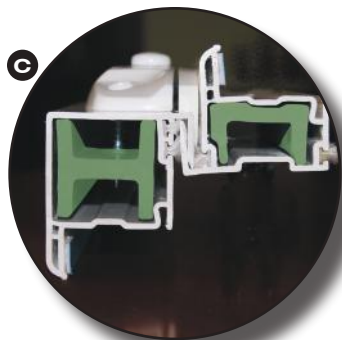

- Full length Sash Interlock with dual weather-strip.
- Sill Interlock **C** secures lower sash.
- Dual Vent Latches provide security.
- Extruded Screen Frame for durability
- Dual CamLocks **B** are securely anchored into the sash reinforcement.
- Horizontal Screws **G** secure lock keeper to reinforce against forced entry.
- Upstand Leg **H** on window sill nests inside lower sash for additional defense against air and water.
- Shadow Grooved Sashes **I** provide clean and uniform corners.
- Flex Screens **J** are standard on all windows ordered with full screen

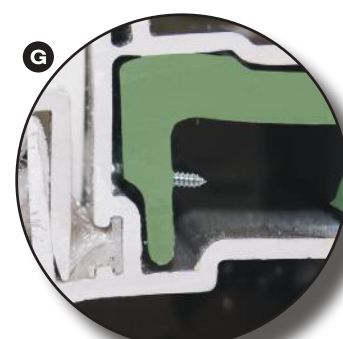
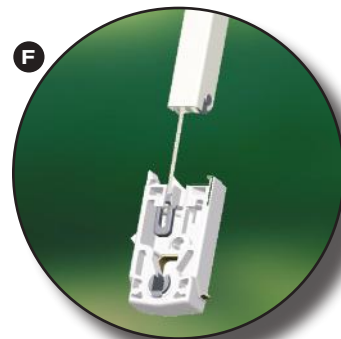
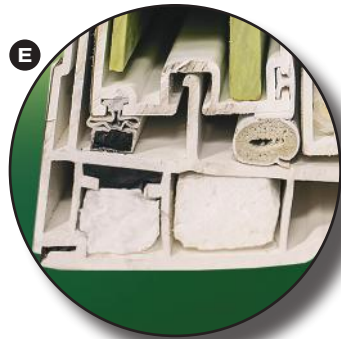
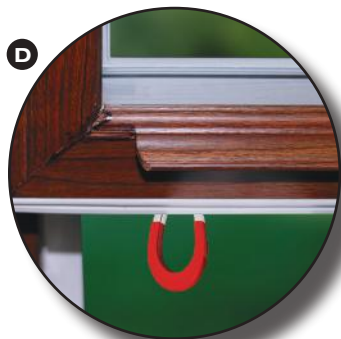

### Ease of Use

- **EZ-Tilt™ B** and Lock Hardware System.
- **EZ-Lift™ F** balance system for smooth operation.
- Block and Tackle balance system.



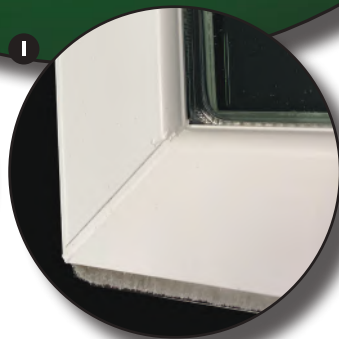
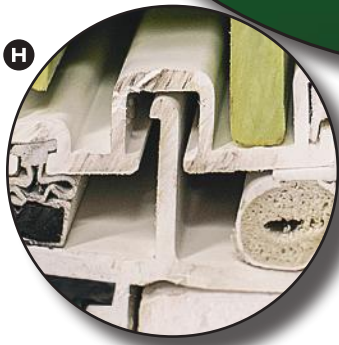
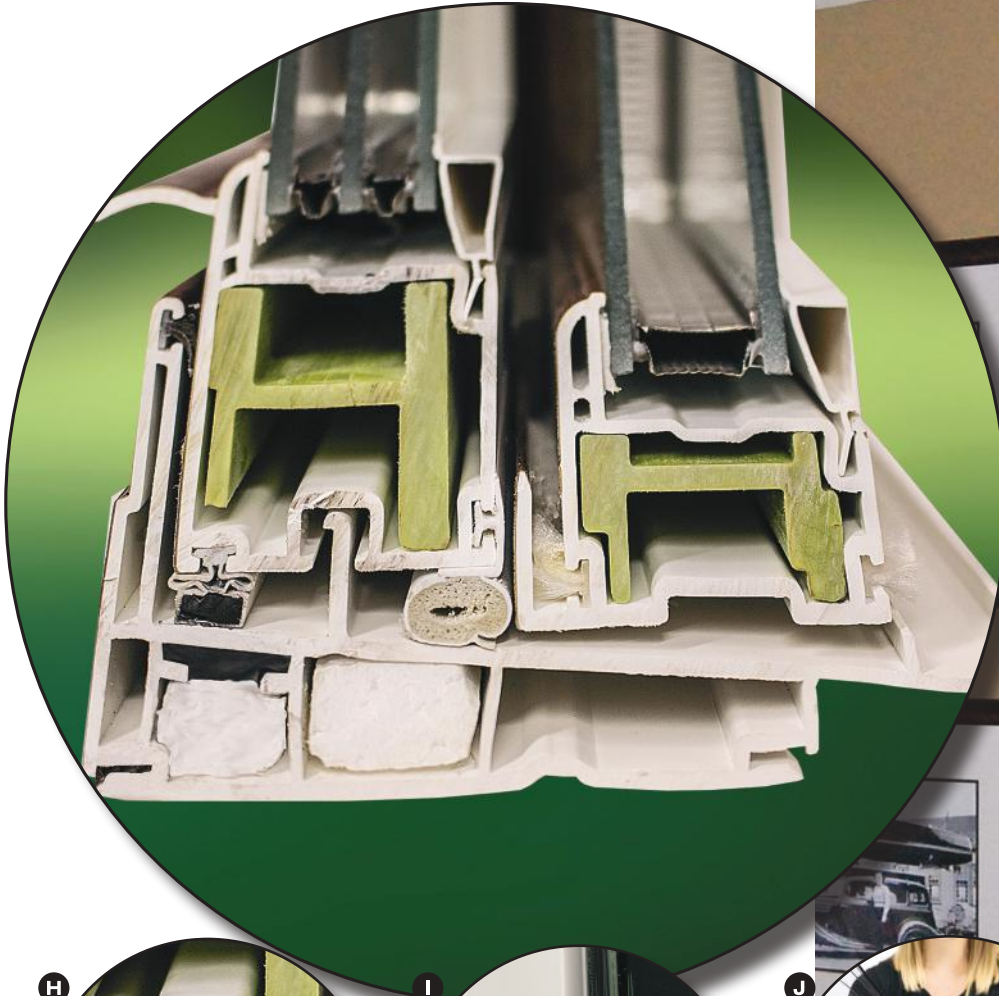

**INNERGY™**  
Rigid Thermal Reinforcements

A soy-based reinforcement product that performs 700% better than aluminum.  
Very green. Very strong.

Design Pressure Rating (Light Commercial): LC 55  
Air Infiltration: 0.04

# Innovations SLIDER WINDOWS

## AN EXCEPTIONALLY SMOOTH OPERATOR

Sliding windows are a popular choice for many homeowners today due to their great appearance and cost effectiveness. Since the Innovations Sliding window utilizes virtually all of the same outstanding features found in our double hung, you can rest assured it will perform well in your home. Innovations Sliders are offered in 2 and 3 Lite styles, and are available with the same colors and options to compliment other window styles.

### Exceptional Beauty

- Exterior Contoured Frame **A** is fusion welded for optimal strength and to be weathertight.
- Equal Sight Lines between sashes maintain the original look of your home.
- Interior Sash detailing offers Traditional millwork appearance.
- Shadow grooved sash corners **B** enhance the finished look of the interior.

### Superior Performance

- High Performance Sill Interlock enhances security and performance in high wind conditions.
- **INNERGY™ C** Composite Reinforcements at meeting rail eliminate sash distortion and bowing.
- **Insul-Core™ D** frame insulation improves the thermal performance over hollow vinyl windows.
- Triple and Quadruple weather-stripping provides a superior barrier against the elements.
- Full length Sash Interlock with dual weather-strip virtually eliminates air infiltration.
- Dual Vent Latches provide added security while window is open for ventilation.
- A premium Extruded Screen Frame with fiberglass mesh is standard on Innovations windows.
- Dual Cam Locks are securely anchored into the sash reinforcement.

### Ease of Use

- Tandem Brass Rollers **E** on both sashes ensure smooth operation for a lifetime.
- Contoured Lift Rails are carefully designed into the sashes and simplify window operation.
- Easy Lift Out sash design enables simple removal of both sashes for quick cleaning from the inside.

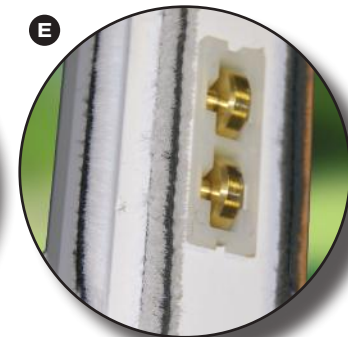
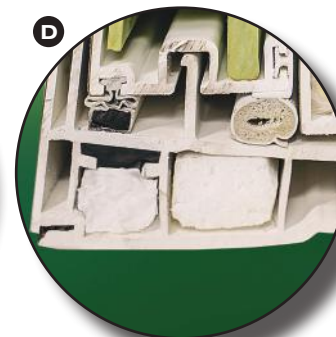
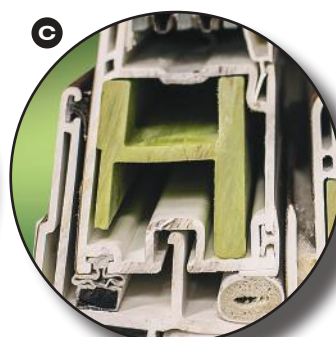
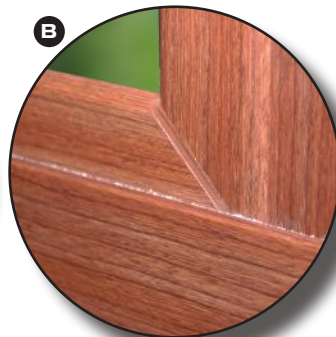
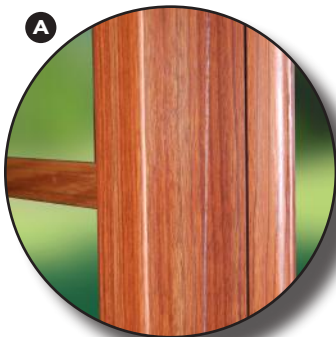



Design Pressure Rating (Light Commercial): LC 60  
Air Infiltration: 0.09

# Innovations CASEMENT & AWNING WINDOWS

## MAXIMIZE YOUR VIEW

Add a touch of elegance to your home with the Innovations Casement Window. Also available in a matching Awning window, these two styles of windows offer the ultimate in performance against high winds and cold temperatures. Utilizing the Vista-View Sash design, Innovations casements offer unobstructed views by maximizing the glass area by reducing the size of sash and frame. To further compliment your home, our casements and awnings are available with the same wide range of color and glass options found with our other window styles.

### Exceptional Beauty

- Fusion welded Contoured sash profile **A** compliments double hung and slider styles.
- **Vista-View™** Sash utilizes narrower sash proportions to offer maximum glass viewing area.
- Continuous Frame design for multi-lite casement units delivers a more traditional appearance.
- Nesting Hardware **B** neatly folds out of the way as to not interfere with blinds or drapes.

### Superior Performance

- Triple weather-stripped frame **C** and sash design delivers air tight performance.
- Multi-point Hardware system ensures a secure and weather tight seal on every window.
- Heavy-Duty Screen Frame with Recessed Screen Clips deliver an uncluttered interior appearance.
- Adjustable Sash system ensures the sash sits squarely in the frame for optimal performance.
- Dual Cam Locks are securely anchored into the sash reinforcement.

### Ease of Use

- Dual Arm Operator provides smooth and efficient operation during opening and closing.
- Casement sashes can be opened to 90° for ease of cleaning from inside the home.
- Single Lever locking system **D** allows easy access to hardware for most every user.



Innovations casement windows are available in multi-sash, single-frame configurations to minimize the frame and maximize your view and ventilation.

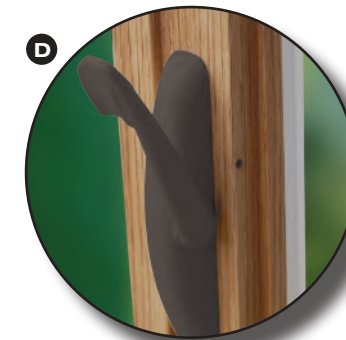
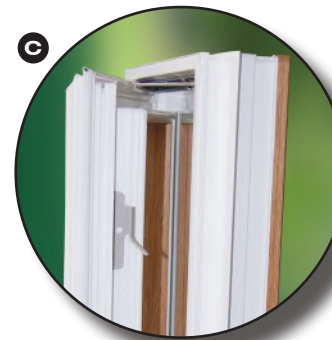
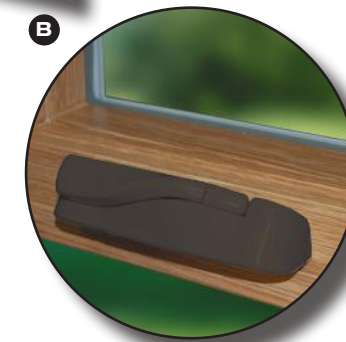





Design Pressure Rating - Picture Window (Heavy Commercial): HC 75  
Air Infiltration: 0.01

# *Innovations* PATIO DOORS



*Tilt, Raise & Lower Mini-Blinds available in standard and custom sizes.*

# Innovations PATIO DOORS

## Premium Patio Door Features



Alloy monorail system creates the EZ Glide sash feature.



Heavy wall multi-cavity frame & sash makes this door the top performer in its class.



Self-adjusting top and bottom screens create the EZ Glide feature.

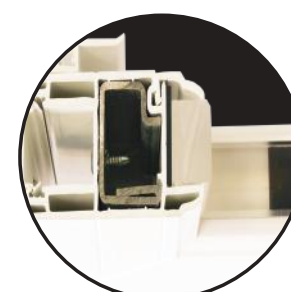

Heavy metal reinforcements in sash profiles.



High-tech Ultrex rollers outperform brass rollers for easy glide and longevity.



Two-point adjustable receiver increases security and insures a tight fit.

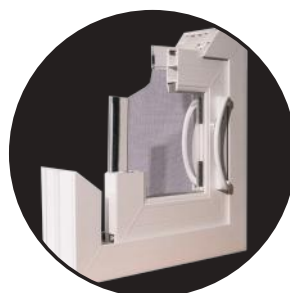

European design that exceeds strict Canadian and US energy codes.



Multi-point locking system for tight fit and added security.



## Available Handle Options



Standard White



Premium Antique Brass



Premium Black Nickel



Premium Bright Brass



Premium Brushed Chrome



Premium Oil-Rubbed Bronze



# Innovations BAY/BOW WINDOWS

## Hand Finished Bay and Bow Window Interiors

To compliment the beautiful interior wood grain finish on Innovations Bay and Bow windows, they are now available with the option of a hand rubbed stain applied to the oak or birch seat boards and interiors. The available stains are Light Oak, Dark Oak, Cherry and Brazilian Pecan. All stains are carefully applied by the Amish artisan finishers and are protected by our famous furniture grade Guard Coat. For a finishing touch, interior trim is available in the same stains in oak in four sizes to fit your custom installation.



## EXPAND YOUR HORIZON

No matter what your view, enjoy it more with an Innovations Bay or Bow window. This terrific option not only brings the outside in, but dramatically enhances the curb appeal of your home. Structurally sound, and highly efficient, Innovations Bay and Bow windows deliver panoramic views while maintaining the comfort level inside your home year round. Drawing upon the same great features found in our standard Double-Hung and Casement windows, Innovations Bay and Bow windows offer a completely maintenance free exterior utilizing high impact uPVC vinyl.

On the interior, traditional wood window styling is combined with several available color options that will enhance your rooms décor. The Innovations Bay and Bow window system also features your choice of Oak or Birch seat boards which can be painted or stained to match virtually any room. An optional insulated seat board can be added for the ultimate in energy efficiency. Bay windows are available with double-hung or casement windows, while Bow windows feature four or five lite casement window configurations. Garden windows project out from the house with an interior shelf for plants and herbs, and feature side vents provide ventilation.



## TimberLand®

The Innovations TimberLand® window boasts a beautiful, heavy-gauge laminate that creates the look of real wood without the maintenance or problems of real wood (like rotting and warping). In fact, these windows require NO maintenance (except for the occasional washing). Classic styling, surprising affordability, and extra high-energy efficiency make the TimberLand® series the choice for homeowners who want the very best.

### Internal Blinds

Internal blinds add style to your window while providing the opportunity to control lighting and privacy. So easy to use, yet completely maintenance-free – you will never clean or dust your blinds again. Each blind is sealed between two panes of glass making this the perfect choice for homes with children or pets. Internal mini-blinds are available in white and almond for most window types. Casement and awning windows can be ordered with blinds, however the screen must be removed to operate the blind. See your Innovations representative for further information and available options.



### Simulated Divided Lites (SDL)

For the look of a real wood window and the efficiency of Innovations glass, add Simulated Divided Lites to your windows. Simulated Divided Lites are available in any of our painted colors or in wood grain finishes to match the standard wood grain options of the Innovations line.



### Muntin Bars

Muntin bars are available in a myriad of colors, styles and sizes. For woodgrain interiors, ask for two-tone muntins to match. All muntins are between the glass for easy cleaning. Please see your representative for details on the many custom options available.

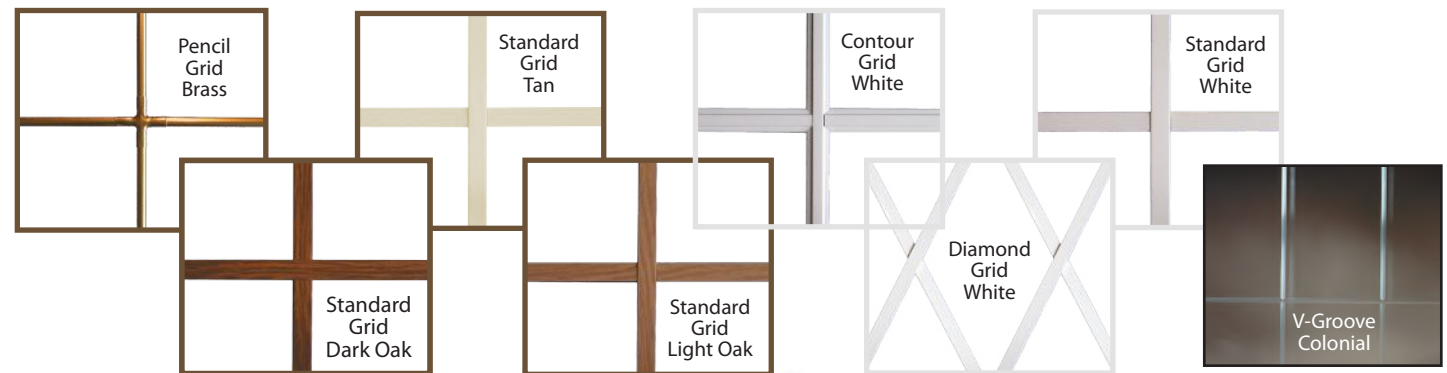

All Innovation style windows are available with optional designer finishes in Antique Brass, Bronze, Satin Nickel and Matte Black.



Antique Brass



Bronze



Satin Nickel



Matte Black



## Innovations Pro Match Exteriors

Innovations windows are now available in 16 beautiful exterior color tones for all window styles and patio doors. Through a special process, these windows can be colorized to compliment many exterior color schemes beyond the scope of standard vinyl colors. These colors are also closely matched to, or complimentary to, our full line of beautiful steel or fiberglass entry door colors.

*Note: Printed colors may vary - please see your dealer for exact color samples.*

### Interior & Exterior Finish Options



\* Black/Black available only on Casement, Awning & Picture windows.

## Pro-Match™ Exterior Options



**PRO•MATCH COLOR SYSTEM**  
All colors marked "\*" are Pro-Match colors.

# Innovations

## HGI's Exclusive Color Match System

Innovations Windows are now available in colors to match our Entry Door Systems as well as our Sliding Patio Door systems. HGI can also supply exact color matched No- Mar finished coil stock for any exterior capping or trim that matches the doors and windows.



### Flex Screen



Home Guard established a strategic partnership with FlexScreen – the world's first and only flexible window screen - as seen on ABC's Shark Tank! FlexScreen's innovative problem-solving design makes installation and removal a breeze. The phosphate enhanced spring steel frame, coated with an exterior grade, high-performance PVC, provides outstanding scratch and weather

resistance and is durable enough to last a lifetime. No aluminum, no paint, no hardware, and no hassle. Just a beautiful uninterrupted view! Flex Screens are standard on all windows ordered with full screen or painted and are always available as an option.

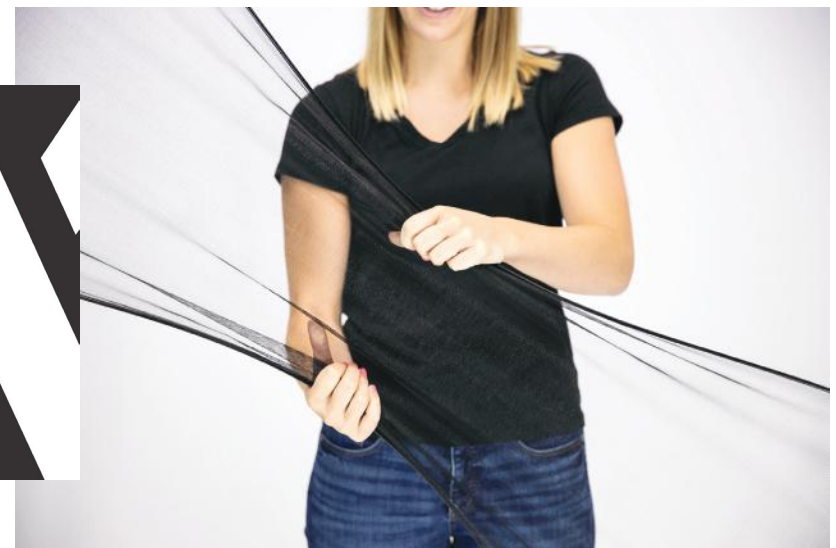



# Conservation

High Efficiency Windows Deserve High Efficiency Glass



## Conservation 100

### High Efficiency Insulated Glass System/Double Pane Clarity & Triple Pane Performance

- Lifetime Seal Failure Warranty
- Lowest Seal Failure Rate in the world
- Lifetime Glass Breakage Warranty
- 24 U-Factor (center of glass only)
- Dual Seal (P.T.B. & Silicone)
- Edge/Guard Stainless Steel Spacer System



### Thicker Glass = Less Noise

Where most window manufacturers use single strength glass to save money, Conservation uses only double strength. Double strength glass provides better sound deadening quality, is more resistant to accidental breakage and is smoother, less wavy than single strength glass, yielding a clearer view.

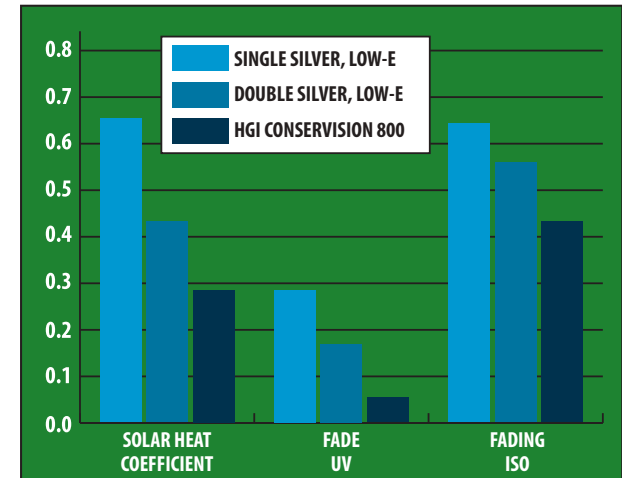

*Smaller Bars/Better Rating*

## THE BIGGEST AND BEST IN THE BUSINESS. PERIOD.

Conservation glass is designed and manufactured by the world's largest and most experienced glass insulator. Our glass is assembled using two separate seals, one on the spacer and one on the back side of the spacer. Because of the research and design of the Conservation glass we can prove that the chance of ever having a seal failure is one quarter of one percent after 20 years. As a matter of fact, in a laboratory comparison of seal failures, Conservation glass will outperform the next largest selling insulated glass by over 400%.



## Conservation 800

### High Efficiency Insulated Glass System/Double Pane Clarity & Triple Pane Performance

- Triple Coated Silver Low-e Plus + Pane of Low Iron, Low-e (Clearer than clear glass)
- Center of Glass only U-Factor: 0.19 (Triple pane clear is 0.39)
- Dual Sealed Units/Polyisobutylene (P.T.B.) & Silicone
- Double Strength Glass (Most windows use single strength to save money.)
- Lifetime Seal Failure Warranty
- SGGC (Solar Heat Gain Coefficient): 0.27 (The lower the number, the better for preventing the sun's heat from entering during summer season).
- Stainless Steel Warm Edge/Guard Spacer to provide warm edge of glass.
- Lowest Seal Failure Rate in Industry. (Beats closest competitor by 1600%.)

Conservation 800 is the most advanced dual pane glass technology available anywhere today. Conservation 800 combines the high efficiency heat saving and heat reflecting properties of the best triple silver low E glass with a second low E glass pane on the inside of the home. The inside Low E aids in reflecting the heat from your home's furnace back into the house. Because it is on a touchable surface, it is encased in a thin layer of low iron glass which actually makes it clearer than clear glass.





# Does HGI Glass Really Matter?

## 15 Protective Layers on 2 Surfaces

HGI's ConserVision 800 is a technological wonder. Multiple layers of silver, metal oxide, protective layers and argon gas combine to insure that heat stays inside in the winter and outside in the summer. Dual-pane ConserVision 800 outperforms most triple-pane units and provides greater clarity and longevity.

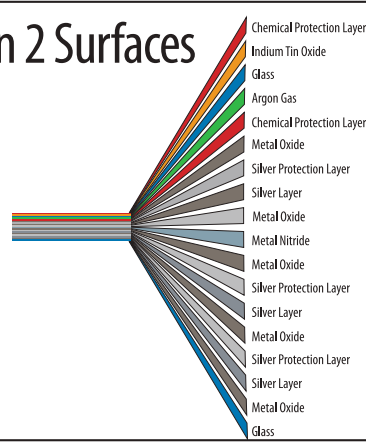

Glass is glass, right? Well actually, not at all. Window glass is all about efficiency - keep the outside out and the inside in. The best way to achieve this is by combining multiple technologies. Glass coatings, a thin layer of UV reflective material, are the first defense. The second is the spacer which separates the layers of glass. HGI utilizes non-conductive, state-of-the-art spacer technology with the lowest failure rate in the industry, backed by our lifetime warranty. Multiple layers of glass are the third. But more layers have proven to be less efficient than just two with coatings on each side of each pane (2 is greater than 3). HGI's ConserVision choices have been specially formulated to reject the sun's heat, letting in more light in and keeping more heat out in the summer, while retaining heat during winter. Your home stays cool and comfortable through every season. Condensation is virtually eliminated, providing a healthier atmosphere inside. What's more, ConserVision provides exceptional fading protection, blocking the sun's damaging ultraviolet rays (a leading cause of fading), keeping your furniture, carpets, curtains and wall coverings beautiful for years to come.

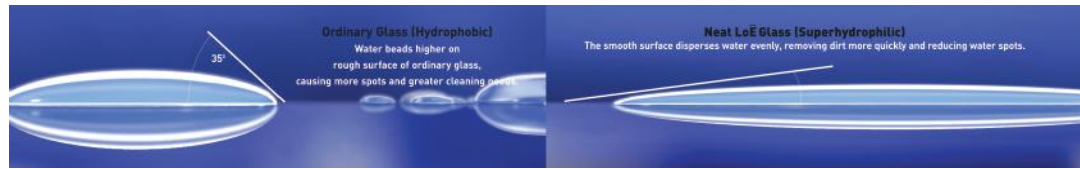

*Windows that almost clean themselves.*

Super smooth Clean/Guard coating will provide you with cleaner, low-maintenance glass. Clean/Guard harnesses the sun's UV rays to loosen dirt so water can rinse it away, leaving windows virtually spotless. Your windows will stay cleaner longer and will clean easier. Enjoy the effects that a little sun, rain and Clean/Guard glass brings to your windows, including a home that stays cooler in the summer and warmer in the winter. Clean/Guard must be ordered in conjunction with ConserVision glass with energy saving Low-e coating. Clearly, Clean/Guard glass is the choice for your windows.



## How we preserve perfect glass from factory to installation.

Cover/Guard is the clear solution to window protection. This patented film defends your glass. Factory-applied to both the outer and inner surfaces in overlapping layers, it ensures that the entire glass surface is protected. When the construction is complete, the film is removed and only perfectly clear and beautiful windows remain. Cover/Guard is an option on all Home Guard windows and will be applied automatically on all Clean/Guard units.



## Clearly Better

Introducing a revolutionary, super transparent new screen material with high-tech fiber that allows excellent protection against unwanted pests, but appears very clear (nearly invisible). Now available as an option on all operational Innovations windows. **Ask to not see it today!**

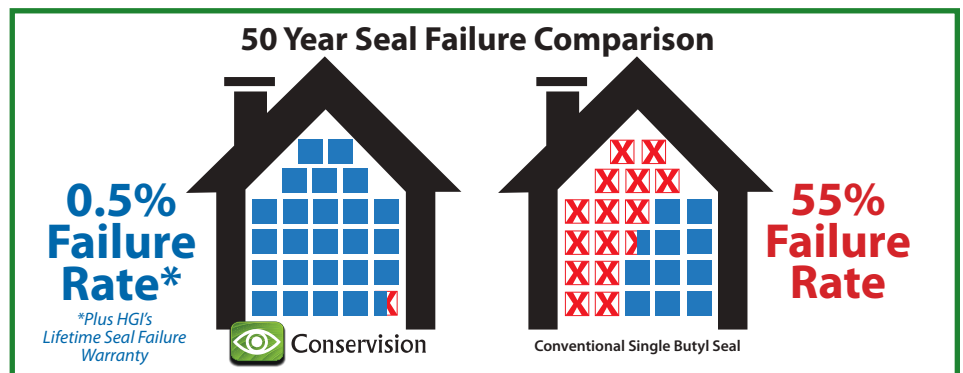



## Buy With Confidence.



Innovations Door & Window Systems is a proud member of EarthWise LLC. EarthWise is a multi-national organization comprised of thirteen manufacturers who share technology, buying power, and provide security to the homeowner through shared responsibility of warranty claims in the event that a member company ceases to exist.

As an EarthWise customer, you have assurance that your windows are supported by fifteen independent manufacturing facilities.



Contact your Innovations dealer for information on architectural shaped or custom-size windows.

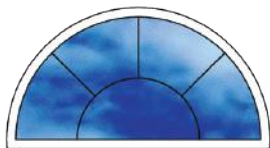

Half Round

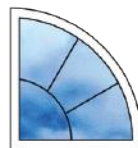

Quarter Round

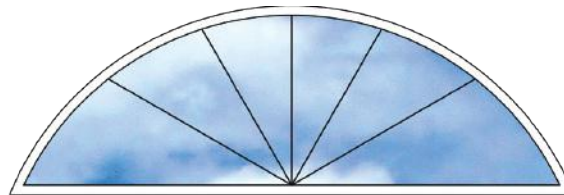

Eyebrow



Octagon



Hexagon



Pentagon

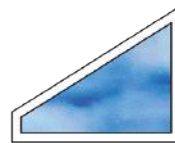

Trapezoid

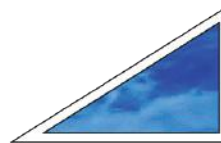

Triangle

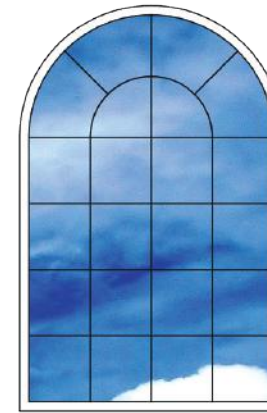

Extended Half Round

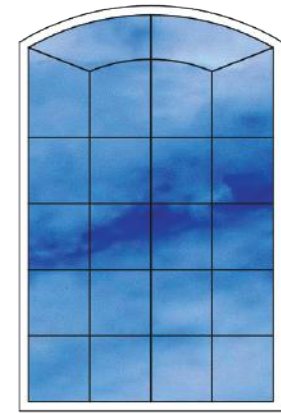

Extended Eyebrow



*Innovations*

- Lifetime
- Non-Prorated
- Transferable
- Glass Breakage

**Protecting your Investment.**

Innovations Windows and Doors are covered by an industry leading warranty unlike any other. Simply put, for as long as you own your home, all components of the Innovations products will be covered in the event of any defects or failures. Case closed. **Innovations Windows and Doors...** Nothing left to chance!



# Innovations

## WINDOW & DOOR SYSTEMS

OTHER HIGH QUALITY PRODUCTS FROM *Innovations*



STEEL ENTRY SYSTEMS



SECURITY STORM DOORS



FIBERGLASS ENTRY SYSTEMS



ALUMINUM STORM DOORS

Innovations Window & Doors Systems is a proud member of EarthWise LLC. EarthWise is a multi-national organization comprised of thirteen window manufacturers who share technology, buying power, and provide security to the homeowner through shared responsibility of warranty claims in the event that a member company ceases to exist. As an EarthWise customer, you have assurance that your windows are supported by thirteen manufacturing facilities.

©2024 Innovations Window & Door Systems • PO Box 39 • Grabill, IN 46741

[www.homeguardindustries.com](http://www.homeguardindustries.com)

Authorized Innovations Dealer:



Conservision



American  
Architectural  
Manufacturers  
Association